

**1.5 ton
CBD15
Mini Electric Pallet Trucks**

- **Operator handle**
Ergonomically designed handle for operator comfort and ease of use. Variable speeds available allowing the operator to increase or decrease speeds to suit each varying situations.
- **Multi-function instrument**
Easy read LCD hour meter and battery discharge indicator (BDI) in one integral unit.
- **Sealed stabilizer wheels**
Maintenance free sealed stabilizer wheel units eliminate damage from shrink wrap and banding material, whilst optimizing stability.

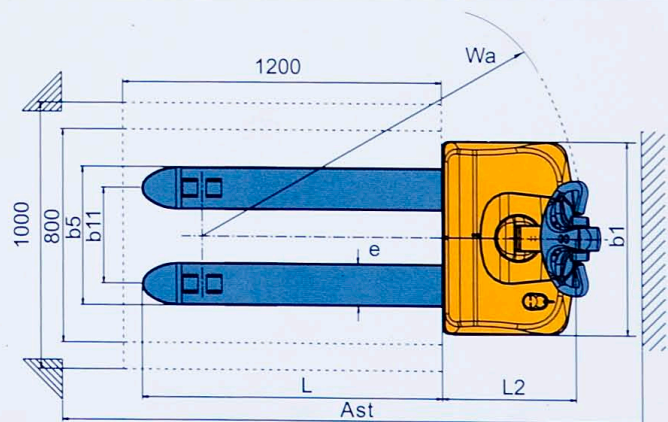

Characteristics			
1	Model Designation		CBD15
2	Configuration Number		610
3	Power type		electric(battery)
4	Operator Type		pedestrian
5	Load capacity	Q(kg)	1500
6	Load center	c(mm)	600
7	Wheelbase	y(mm)	1234
Wheels			
8	Tyre Type		PU
9	Tyre Size, drive	mm	φ 252*67
10	Tyre Size, load	mm	φ 80*58/ c 73*98
11	Stabilizer wheels (size)	mm	φ 99.5*40
12	Wheels number, Stabilizer/load (x=driving wheels)		1X+2/4, 1X+2/2
13	Tread, rear	b11 (mm)	488
Dimensions			
14	Handle in neutral position	h14(mm)	1220
15	Overall Length	L1 (mm)	1650/1700
16	Length to face of forks	L2(mm)	500
17	Overall Width	b1(mm)	724
18	Maximum Lifting height	h3(mm)	120
19	Height, fork lowered	h13(mm)	74/85
20	Fork Thickness	s(mm)	44
21	Fork Width	e(mm)	160
22	Fork Length	L(mm)	1150/1200
23	Width overall forks	b5(mm)	540/570/600/685
24	Outside turning radius	Wa(mm)	1400
25	Right angle stacking aisle width for pallets 800×1200 mm(clearance: 200)	Ast(mm)	1820
26	Right angle stacking aisle width for pallets 1000×1200mm(clearance: 200)	Ast(mm)	1865
Performance			
27	Travel speed, with/without load	km/h	3.5/4
28	Lifting speed, with/without load	mm/s	56/60
29	Lowering speed, with/without load	mm/s	57/59
30	Gradeability, with/without load	%	5/7
31	Service Brake		Electromagnetic brake
Motor			
32	Drive motor power	kW	DC0.6
33	Lift motor power	kW	DC0.8
34	Battery voltage/capacity	V/ Ah	24/70Maintenance free
Weight			
35	Battery Weight	kg	48
36	Weight (include battery)	kg	292

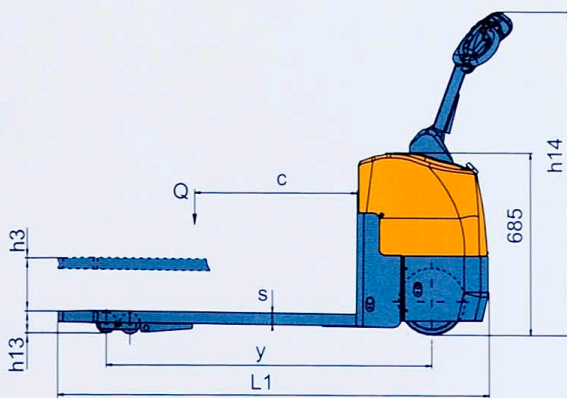

CBD15-610